

CA45H Series High Temperature Epoxy Molded Solid Electrolytic Chip Tantalum Capacitor

※(Can replace KEMET's T498,VISHAY's TH3 Series' High TemperatureR Capacitors)

Brief Introduction

- Epoxy molded encapsulation,Chip,Heteropolarity;
- Small in size,Light in weight,Stable in electrical & storage performances, Long life-span,High reliability;
- Excellent working ability under High Temperature,Available in 150°C;
- Applying in Petroleum Deep-well's measurement & drilling such High-Temperature resistance Electrical Equipments with High-reliable SMT circuit for Military and Civil use;
- Operative Standard:QJ/PWV326-2010;
- Ordering Information:CA45H-685K050ET:1000 pcs.

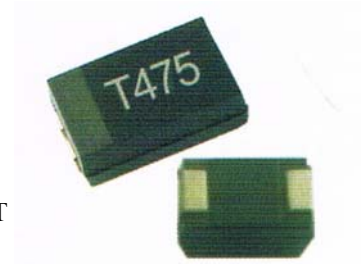

Features

- Operating Temperature Range: -55°C~+150°C(When $> +85^{\circ}\text{C}$,with rated voltage derating);
- Capacitance Tolerance:K:±10%; M:±20%;
- DC Leakage at 25°C: $I_0 \leq 0.01C_R U_R (\mu\text{A})$ or $0.5\mu\text{A}$ (Choose the greater one) ;
- Rated Voltage,Category Voltage,Surge Voltage,Nominal Capacitance,ESR:See Table 3 & Table 4;
- Dimensions:See Figure & Table1;
- Temperature Characteristics:See Table 2.

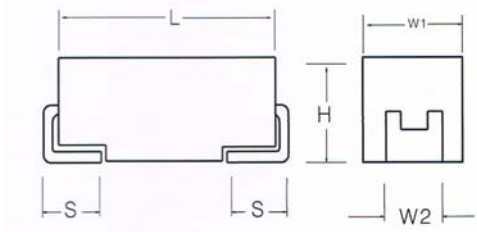

Table1 Dimensions (mm)

Case Code	L±0.2	W1±0.2	H±0.4	S±0.2	W2±0.2
A	3.2	1.6	1.6	0.8	1.2
B	3.5	2.8	1.9	0.8	2.2
C	6.0	3.2	2.5	1.3	2.2
D	7.3	4.3	2.8	1.3	2.4
E	7.3	4.3	4.1	1.3	2.4

Table2 Temperature Characteristics

Nominal Capacitance C_R (μF)	Max											
	Range of Capacitance (%)				tg δ (%)Max					DCL (μA)		
	-55°C	85°C	125°C	150°C	-55°C	25°C	85°C	125°C	150°C	85°C	125°C	150°C
≤ 1.0	± 10	± 10	± 12	± 15	6	4	6	6	8			
1.5~68					8	6	8	8	10	10 I _o	12.5 I _o	15 I _o
100~220					10	8	10	10	15			

Marking Specification

For example: 10V2.2 μF

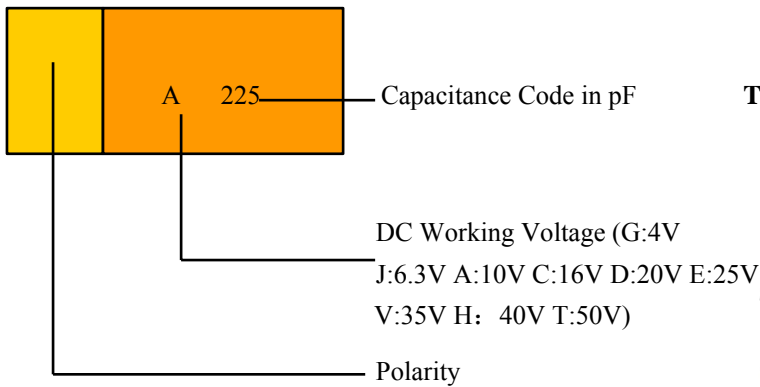

Packing

T=Tape and reel
B=bulk pack

Taping and Packing

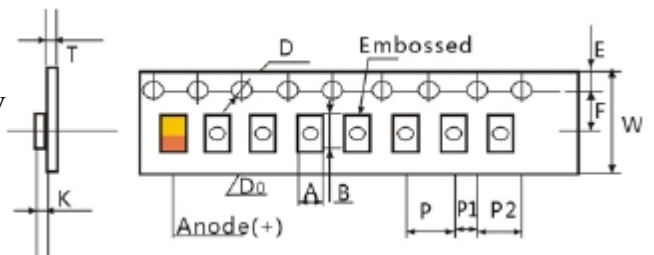

Carrier Tape Dimension

Unit:mm

Case Size	A ± 0.2	B ± 0.2	P ± 0.1	E ± 0.1	F ± 0.1	W ± 0.1
A	1.90	3.50	4.00	1.75	3.50	8.00
B	3.10	3.80	4.00	1.75	3.50	8.00
C	3.60	6.40	8.00	1.75	3.50	12.00
D	4.70	7.70	8.00	1.75	3.50	12.00
E	4.60	7.60	8.00	1.75	3.50	12.00
V	6.40	7.60	8.00	1.75	4.40	12.00

Reel Dimensions

Unit:mm

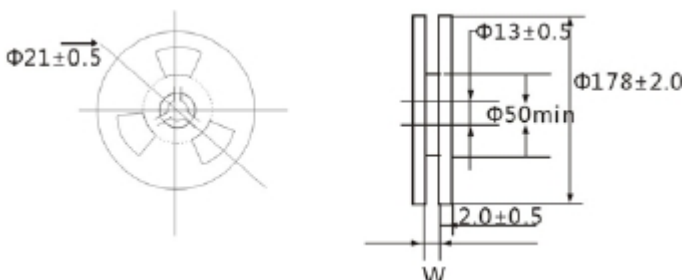

Case Code	W	Qty/reel
A、B	8.4 ^{+1.5} ₀	2000
C、D	12.4 ^{+2.0} ₀	500
E	12.4 ^{+2.0} ₀	400
V	12.4 ^{+2.0} ₀	400

Ordering Information

CA45L	105	M	035	A	T
Type	Capacitance Code	Tolerance	DC voltage	Case Size	Packaging
Chip Tantalum Capacitor	105 = $10 \times 10^5 \mu\text{F} = 1 \mu\text{F}$ 105 10×10^5 (pF) this is expressed in pico farads, the first two digits are the significant figures, the third is the number of zeros to follow	K= $\pm 10\%$ M= $\pm 20\%$	4V=004 6.3V=006 10V=010 16V=016 20V=020 25V=025 35V=035 40V=040 50V=050 63V=063 75V=075 100V=100	A:3.2*1.6 B:3.5*2.8 C:6.0*3.2 D:7.3*4.3 E:7.3*4.3 V:7.3*6.1	T=Tape and reel B=bulk pack

Table 3 Electrical Characteristics

Rated Voltage U_R (V)	6.3	10	16	20	25	35	40	50
Category Voltage U_C (V) at 125°C	4	6.3	10	13	16	20	25	32
Category Voltage U_C (V) at 150°C	3	5	8	10	12	17	20	25
Nominal Capacitance C_R (μF)	Case Code							
0.33					A	A		
0.47					A	A		
0.68					A	A	C/B	
1.0			A	A	B/A	B	C/B	C
1.5		A	A	A	B	C/B	C/B	C
2.2	A	A	A	B/A	B	C	D/C	C
3.3	A	A	B/A	B	C/B	C	D/C	D
4.7	A	A	B/A	C/B	C/B	D/C	D	D
6.8	A	A	B	C	C	D/C	D	E
10	A	B	B	C	D/C	D	E/D	E
15	B	B	C/B	D/C	D/C	E/D	E	
22	B	C/B	C	D/C	D	E		
33	B	D/C	D/C	D	D			
47	C/B	D/C	D/C	E/D	E			
68	C/B	D/C	D	E				
100		D	E					
150		E						
220		E						

Table 4 ESR at +25°C

Rated Voltage $U_R(V)$		6.3	10	16	20	25	35	40	50
Nominal Capacitance $C_R(\mu F)$	Case Code	Max ESR (100KHz) at 25°C							
0.33	A					15	18		
0.47	A					14	18		
0.68	C							8.0	
	B							15	
	A					17	17		
1.0	C							6.5	6.0
	B					6.5	6.5	10	
	A			10	10	16			
1.5	C						4.5	4.5	8.0
	B					6.5	12	10	
	A		8.0	8.0	16				
2.2	D							3.5	
	C						3.5	7.0	7.0
	B				5.0	8.0			
	A	8.0	8.0	8.0	12				
3.3	D							2.5	2.0
	C					4.0	2.5	5.0	
	B			5.5	4.0	7.0			
	A	8.0	9.0	9.0					
4.7	D						1.5	1.5	1.5
	C				3.0	2.5	5.0		
	B			4.0	6.0	6.0			
	A	8.0	8.0	8.0					
6.8	E								1.5
	D						1.3	1.3	
	C				2.4	3.0	3.0		
	B			6.0					
	A	8.0	8.0						
10	E							1.3	1.8
	D					1.2	1.1	2.0	
	C				4.0	4.0			
	B		6.0	6.0					
	A	8.0							
15	E						1.1	1.8	
	D				1.1	1.0	2.0		
	C			1.8	4.0	4.0			
	B	5.0	5.0	5.0					

Table 4 ESR at +25°C,Continued

Rated Voltage $U_R(V)$		6.3	10	16	20	25	35	40	50
Nominal Capacitance $C_R(\mu F)$	Case Code	Max ESR (100KHz) at 25°C							
22	E						1.0		
	D				0.9	1.8			
	C		1.6	3.0	3.0				
	B	5.0	5.0						
33	D		1.1	0.9	1.5	1.5			
	C		2.5	2.5					
	B	3.5							
47	E				0.8	1.2			
	D		0.9	1.5	1.5				
	C	2.0	2.0	2.0					
	B	3.0							
68	E				0.8				
	D		1.5	1.5					
	C	2.0	2.0						
	B	4.2							
100	E			0.8					
	D		1.2						
150	E		0.8						
220	E		1.0						

P.S. : 1 Please do not use multimeter through the measuring procedures.

2 Capacitance and DF measured at :100Hz, $U_{\sim}=2.2^{+0.10}V$, $U_{\sim}=1.0^{+0.05}V$, Frequency=100Hz.
Test only applied in series equivalent circuit.

3 Voltage derating is applied at +125°C. (The DCL parameter should be read after 5minutes when it connected to the circuit) .

4 Special size and demand could consult with us.